

CYLINDRICAL SHANK

MEGA MICRO CHUCK	P85
MEGA NEW BABY CHUCK	P86
NEW BABY CHUCK	P87

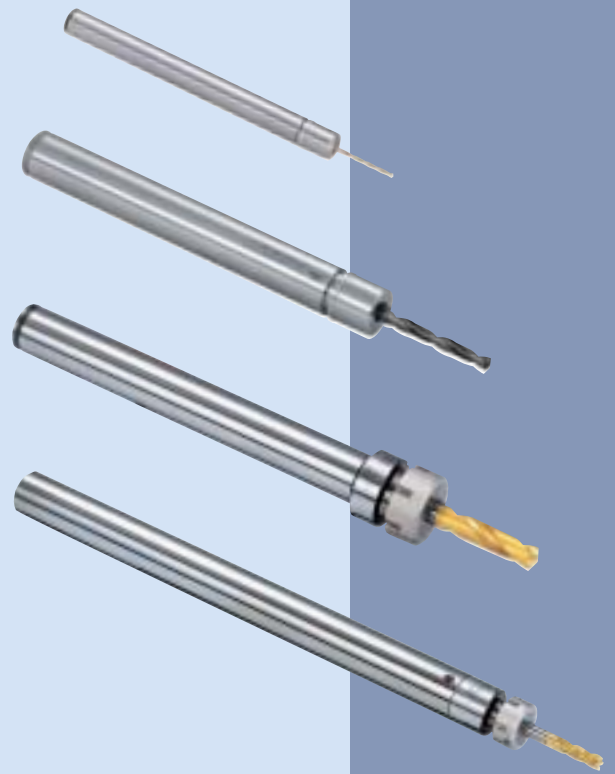



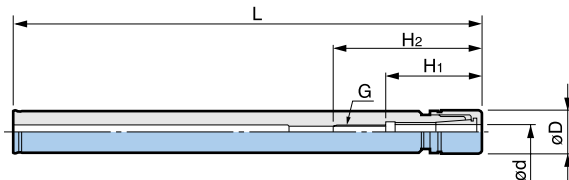

MEGA MICRO CHUCK[®] PAT. Clamping Range : \varnothing 0.45 - \varnothing 6.05

\varnothing 10 ultra small dia. to avoid interference.
High precision is maintained by combination with
MEGA NEW BABY CHUCK.



Model	Clamping Range \varnothing d	\varnothing D	L	H1	H2	G	Collet Model	Nut Model	Weight (kg)
ST10-MEGA3S-120	0.45 – 3.25	10	120	22	38	M4 P0.7	NBC3S-□	MGN3S	0.06
ST12-MEGA4S-130	0.45 – 4.05	12	130	26.5	47	M5 P0.8	NBC4S-□	MGN4S	0.11
-160			160						0.13
ST14-MEGA6S-160	0.45 – 6.05	14	160	28.5	49	M7 P0.75	NBC6S-□	MGN6S	0.18
-200			200						0.21

1. MEGA NUT is included.

	Spare Parts	Accessories			
	MEGA NUT 	MEGA WRENCH 	MICRO COLLET  P91	MICRO COLLET PROTECTIVE CASE 	α TAPER CLEANER 
MEGA MICRO CHUCK	Model	Model	Model	Model	Model
MEGA3S	MGN3S	MGR10	NBC3S-□	NBB3S	SC-NBC3S
MEGA4S	MGN4S	MGR12	NBC4S-□	NBB4S	SC-NBC4S
MEGA6S	MGN6S	MGR14	NBC6S-□	NBB6S	SC-NBC6S

MEGA MICRO CHUCK SET



Including convenient storage case.

Set model **SST12-MEGA4S-130**

Contents

< SST12 - MEGA4S - 130 >

- BODY/ ST12 - MEGA4S - 130 (with MGN4S nut)
- COLLET/ NBC4S - 3 & 4 (2 pcs.)
- WRENCH/ MGR12

Set model **SST14-MEGA6S-160**

< SST14 - MEGA6S - 160 >

- BODY/ ST14 - MEGA6S - 160 (with MGN6S nut)
- COLLET/ NBC6S - 3,4,5 & 6 (4 pcs.)
- WRENCH/ MGR14

MEGA NEW BABY CHUCK[®] PAT. Clamping Range : $\varnothing 0.25 - \varnothing 20$

Cylindrical shank models offer flexible solutions against possible interference in combination with MEGA DOUBLE POWER CHUCK.



Coolant-through hole

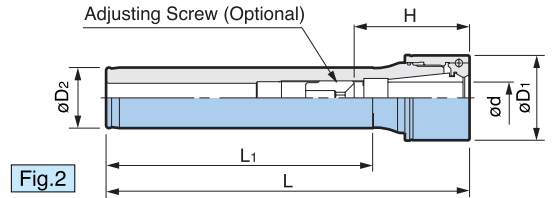
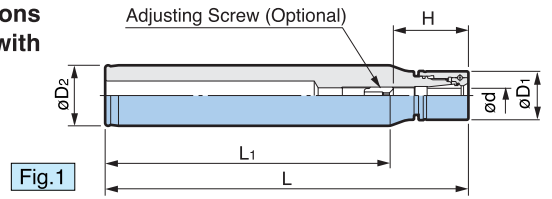

Model	Fig.	Clamping Range $\varnothing d$	$\varnothing D_1$	$\varnothing D_2$	L	L ₁	H	Nut Model	Weight (kg)		
ST20-MEGA 6N-100	1	0.25 – 6	20	20	100	76	23 – 43	MGON 6	0.2		
-150					150	126			0.3		
-250					250	226			0.5		
-MEGA 8N-100	2	0.5 – 8	25		100	65	26 – 45	MGON 8	0.3		
-150					150	115			0.4		
-250					250	215			0.6		
-MEGA10N-100	2	1.5 – 10	30		100	60	38 – 48	MGON10	0.3		
-150					150	110			0.4		
-250					250	210			0.6		
ST25-MEGA 6N-150	1	0.25 – 6	20	25	150	116	23 – 43	MGON 6	0.5		
-MEGA 8N-150					150	123			26 – 45	MGON 8	0.5
-200					200	173					0.7
-MEGA10N-150	2	1.5 – 10	30		150	123	38 – 48	MGON10			0.5
-200					200	173			0.7		
-MEGA13N-150					2	2.5 – 13			35	150	110
-200	200	160	0.7								
ST32-MEGA 6N-150	1	0.25 – 6	20				32	150		113	23 – 43
-MEGA 8N-150					150	111		26 – 45	MGON 8	0.9	
-MEGA10N-150				150	123	38 – 48				MGON10	
-200	200	173	1.1								
-MEGA13N-150	2	2.5 – 13	35	150	120			44 – 63	MGON13		0.9
-200				200	170	1.1					
-300				300	270	1.6					
-MEGA16N-150	2	2.5 – 16	42	150	110	48 – 68		MGN 16	1.0		
-200				200	160				1.2		
-300				300	260		1.7				
-MEGA20N-150	2	2.5 – 20	46	150	105	51 – 68	MGN 20	1.0			
-200				200	155			1.3			
-300				300	255			1.9			

- MEGA NUT is included.
- "H" indicates the adjustment length with an Adjusting Screw.
- BIG** ST LOCK is recommended to mount / release a cutting tool.



Spare Parts		Accessories								
MEGA NUT		MEGA WRENCH		NBC COLLET		SEALING NUT MEGA PERFECT SEAL		ADJUSTING SCREW		
MEGA NEW BABY CHUCK	Model	Model	Model	Model	Model	Model	G	L	B	
MEGA 6N	MGON 6	MGR20	NBC 6-□	MPS 6-□	NBA 6B	M 7	12	2		
MEGA 8N	MGON 8	MGR25	NBC 8-□	MPS 8-□	NBA 8B	M 9	13	2.5		
MEGA10N	MGON10	MGR30	NBC10-□	MPS10-□	NBA10B	M11	16	3		
MEGA13N	MGON13	MGR35	NBC13-□	MPS13-□	NBA13B	M14	20	4		
MEGA16N	MGN16	MGR42	NBC16-□	MPS16-□	NBA16B	M18	20	4		
MEGA20N	MGN20	MGR46	NBC20-□	MPS20-□	NBA20B	M21	20	4		

1. Please be aware that the rubber seal in the Adjusting Screw may be stripped off due to high pressure coolant.

Coolant-through hole

NEW BABY CHUCK PAT. Clamping Range : $\varnothing 0.25 - \varnothing 20$

Avoids interference when used in combination with BIG NEW Hi-POWER MILLING CHUCK.

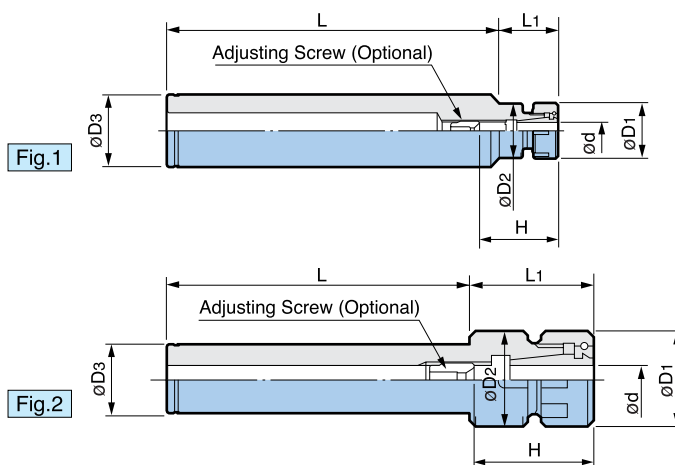

Model	Fig.	Clamping Range $\varnothing d$	$\varnothing D1$	$\varnothing D2$	$\varnothing D3$	L	L1	H	Weight (kg)	
ST20-NBS 6-100	1	0.25 – 6	20	19.5	20	100	24	20 – 40	0.27	
-150						150			0.39	
-250						250			0.64	
-NBS 8-100	2	0.5 – 8	25	24.5		100	26	23 – 42	0.29	
-150						150			0.41	
-250						250			0.66	
-NBS10-100	2	1.5 – 10	30	29.5		100	28	35 – 45	0.32	
-150						150			0.44	
-250						250			0.69	
-350						350			0.93	
ST25-NBS 6-150	1	0.25 – 6	20	19.5		25	150	24	20 – 40	0.60
-200							200			0.79
-250					250		0.98			
-NBS 8-150	1	0.5 – 8	25	24.5	150		26	23 – 42	0.62	
-200					200				0.81	
-250					250				1.00	
-NBS10-150	2	1.5 – 10	30	29.5	150		28	35 – 45	0.65	
-200					200				0.84	
-250					250				1.03	
-NBS13-150					2				2.5 – 13	35
-200	200	0.86								
-250	250	1.05								

1. NEW BABY NUT is included.

For ST LOCK P109

Model	Fig.	Clamping Range ød	øD1	øD2	øD3	L	L1	H	Weight (kg)	
ST32-NBS 6-150	1	0.25 - 6	20	19.5	32	150	24	20 - 40	0.96	
-200						200			1.28	
-250						250			1.59	
-NBS 8-150		0.5 - 8	25	24.5		150	26	23 - 42	0.99	
-200						200			1.30	
-250						250			1.61	
-NBS10-150		1.5 - 10	30	29.5		150	28	35 - 45	1.02	
-200						200			1.33	
-250						250			1.64	
-350						350			1.95	
-NBS13-150		2	2.5 - 13	35		34.5	150	34	41 - 60	1.04
-200							200			1.35
-250	250				1.67					
-300	300				2.30					
-NBS16-150	2.5 - 16				42		41.5			150
-200		200	1.37							
-300		300	2.00							
-NBS20-150	2.5 - 20	46	45.5	150	34	48 - 65	1.05			
-200				200			1.37			
-300				300			2.00			

1. NEW BABY NUT is included.

For ST LOCK P109

Spare Parts		Accessories						
	NEW BABY NUT 	WRENCH 	NBC COLLET For ENDMILL COLLET 	BABY PERFECT SEAL 	ADJUSTING SCREW 			
NEW BABY CHUCK	Model	Model	Model	Model	G	L	B	
NBS 6	NBN 6	NBK 6	NBC 6- □	BPS 6- □	NBA 6B	M 7	12	2
NBS 8	NBN 8	NBK 8	NBC 8- □	BPS 8- □	NBA 8B	M 9	13	2.5
NBS10	NBN10	NBK10	NBC10- □	BPS10- □	NBA10B	M11	16	3
NBS13	NBN13	NBK13	NBC13- □	BPS13- □	NBA13B	M14	20	4
NBS16	NBN16	NBK16	NBC16- □	BPS16- □	NBA16B	M18	20	4
NBS20	NBN20	NBK20	NBC20- □	BPS20- □	NBA20B	M21	20	4

1. Please be aware that the rubber seal in the Adjusting Screw may be stripped off due to high pressure coolant.



Coolant-through hole

Clamping Range : $\varnothing 0.25 - \varnothing 6$

NEW BABY CHUCK PAT. CARBIDE CYLINDRICAL SHANK

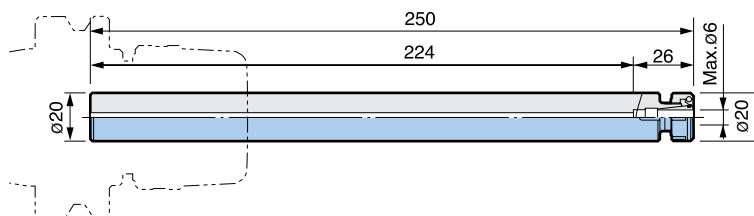
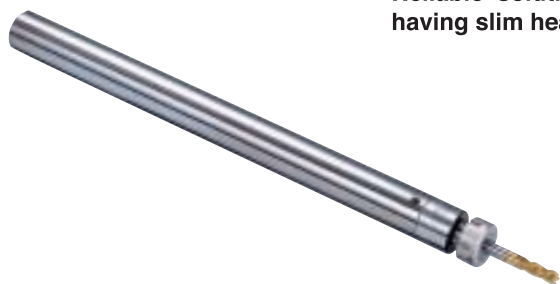
Reliable solution for deep and narrow access
having slim head and solid carbide shank.



Standard Type	
Model	ST20W-NBS6-250 < NBN6 Nut included >
	
Remarks : Collet and Wrench are not included. Weight : 1.20 kg	
Set Type	
Model	SST20W-NBS6-250
Standard Accessory : NBN 6 nut NBK 6 wrench (2 pcs) NBC collets {NBC6 - 3, 4, 5, 6 (AA)}	
	

 For WRENCH **P88**

 For PERFECT SEAL **P98**

 For ST LOCK **P109**

Application Example



Spindle Speed : 1,000 min⁻¹
 Cutting Feed : 0.1mm/rev.
 Cutting Depth : 0.5mm
 Cutter : 5mm Solid Carbide End Mill
 Workpiece : Cast Iron G025 (DIN)
 FC25 (JIS)

NEW HI-POWER MILLING CHUCK

NEW HI-POWER MILLING CHUCK
ensures high accuracy, high rigidity and powerful
gripping force for Carbide Cylindrical Shank
New Baby Chuck.

