

## Straight Collet

High precision straight collet for  $\phi 20$ mm clamping diameter chucks.

### PERFECT JET PAT.



#### Jet Through

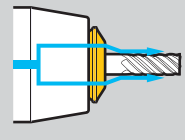

#### Model Description

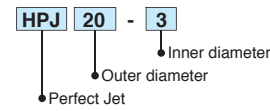

Model	A	Hydraulic Chuck Model
HPJ20 - 3, 4, 5, 6, 7	5.8	HDC20
- 8, 9, 10, 11, 12, -13, 14, 15, 16	7.3	

※ Sealing rubber PS Ring is not required.

### PERFECT SEAL PAT.



#### Through Tool

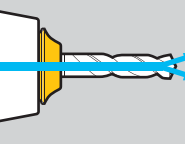

#### Model Description

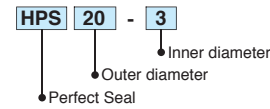

Model	A	Hydraulic Chuck Model
HPS20 - 3	9.4	HDC20
- 4, 5, 6	9.1	
- 7, 8	9.4	
- 9, 10	9.8	
- 11, 12, 13	10.2	
- 14, 15, 16	9.8	

### 《PS RING (For Perfect Seal)》 PAT.



1 package contains 5 pcs. (1 size)

Replaceable seal is installed in the Perfect Seal.

(Replacement of seal is recommended when coolant leaks due to damage of the PS Ring.)

#### For Perfect Seal (HPS)

Model	Corresponding Perfect Seal	Model	Corresponding Perfect Seal	Model	Corresponding Perfect Seal
PS-0304	HPS20-3 -4	PS-0809	HPS20- 9	PS-1314	HPS20-14
0405	-5	0910	-10	1415	-15
0506	-6	1011	-11	1516	-16
0607	-7	1112	-12		
0708	-8	1213	-13		

## TEST BAR

For checking clamping force

Exclusive test bar to check the clamping force of Hydraulic Chucks



Model	Bore Diameter	Model	Bore Diameter	Model	Bore Diameter	Model	Bore Diameter
TSB 6	6	TSB10	10	TSB14	14	TSB20	20
7	7	11	11	15	15	25	25
8	8	12	12	16	16	32	32
9	9	13	13	18	18	42	42

Please refer to the operation manual of Hydraulic Chucks for details.

# BIG

BIG DAISHOWA

# HYDRAULIC CHUCK

BBT/HSK/CAPTO

BIG DAISHOWA SEIKI CO LTD

CATALOG No. EXm 290

Min. 4mm clamping diameter!

For high precision machining in Automotive, Aerospace, Medical and Die & Mold

Precision drills & reamers Ball endmills

Endmills Diamond reamers Grinding tools

Ideal toolholders for machining processes that require high accuracy.

## High precision, smooth and stable cutting

Pre-balanced for high speed machining

MAX. 20,000min<sup>-1</sup>

Runout accuracy less than 3 $\mu$ m at 4d.

Easy clamping/unclamping operations with just 1 wrench



BIG-PLUS tools can be used in machining centers with conventional spindles.



## BIG DAISHOWA SEIKI CO LTD

Takaramachi 5-2, Higashiosakashi  
Osaka 579-8025 JAPAN  
Phone : (+81)-72-982-8277 Fax : (+81)-72-982-8370  
http://www.big-daishowa.com E-mail: export@big-net.ne.jp



JQA-QMA11602  
AWAJI No.1 Factory  
JQA-QM3913  
FA Dept.

CATALOG No. EXm290-0511-1

Subject to technical changes by further developments.

# BIG HYDRAULIC CHUCK



Wide variety of tool diameters and projections to fit any application. Available for simultaneous fit systems and all other major interfaces.

### Runout accuracy less than 3µm

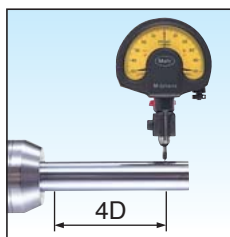

High precision runout accuracy less than 3µm at 4d improves the workpiece surface finish and extends tool life.

(Repeatability is less than 1.5µm.)

### Smallest clamping diameter 4mm

Ideal length and diameter of holder is the key to precision machining. Select the optimum from the wide range.

### Balanced for high speed machining

Pre-balanced to less than 15g·mm. Vibration free machining at high speed.

### Dual contact spindle interfaces (BBT, HSK, CAPTO)

Combined with machine tools with the BIG-PLUS spindle, BIG-PLUS tool holders dramatically improve the drilling accuracy and the surface finish. HSK and CAPTO standards are also available.

### Easy clamping with 1 wrench



The cutting tool can be clamped or unclamped easily and securely with just 1 wrench.

High runout accuracy  
**Less than 3µm**

### Integral sleeve construction

Compared with the traditional two-part construction sealed with O-rings, BIG Hydraulic Chucks are long lasting and maintenance free. Also the rigidity is greatly improved by the short projection length and dual pressure points.

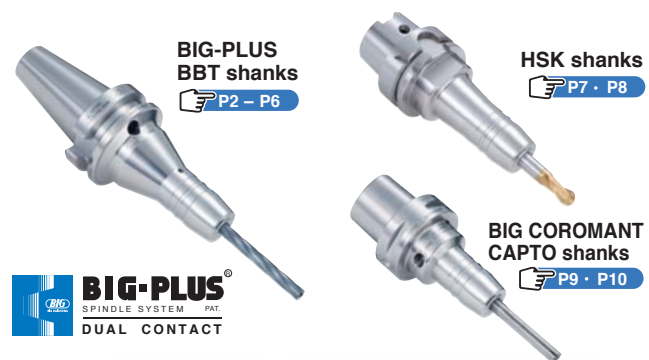
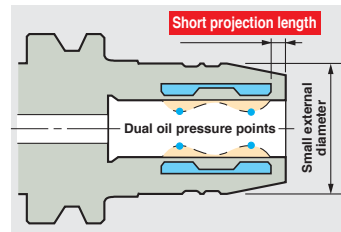

● Wide variety of clamping diameters (1mm increments) & projections

● Simultaneous taper and flange fit BBT/HSK/CAPTO



## BBT30 series

Clamping range:  $\varnothing 4 - \varnothing 32$



Coolant Through Hole

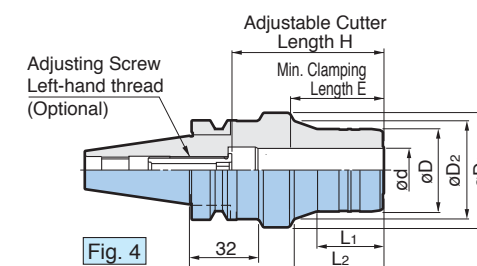
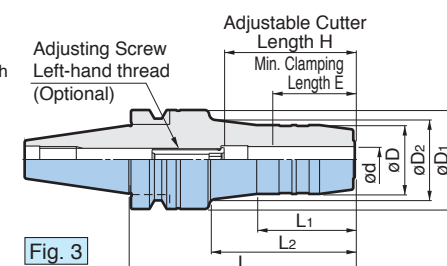
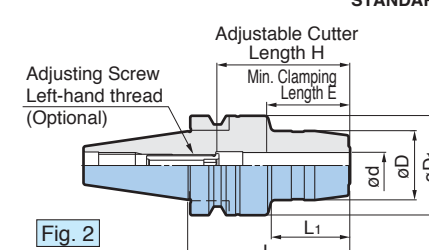
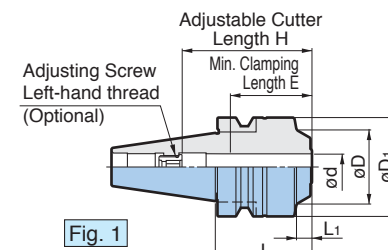

● Model Description  
**BBT30** - **HDC** **4** - **45**  
 ● Projection Length  
 ● Clamping Size  
 ● Hydraulic Chuck  
 ● BIG-PLUS BT No.

### BBT30

BIG-PLUS tools can be used in machining centers with conventional spindles.

Model	Fig.	$\varnothing d$	$\varnothing D$	$\varnothing D_1$	$\varnothing D_2$	L	L <sub>1</sub>	L <sub>2</sub>	Adjustable Cutter Length H	Min. Clamping Length E	Adjusting Screw (Optional)	Weight (kg)
<b>BBT30-HDC 4- 45</b> ▲	2	4	25	45.4	—	45	15	—	—	19	—	0.6
- 60▲						60	30					
- 75▲						75	38					
<b>-HDC 6- 45</b>	1	6	26	45.4	—	45	7	—	35-50	28	HDA 6-05020	0.7
- 75	75					40						
- 90	90					43						
<b>-105</b>	3				31	105	43	57	28-50	28	HDA 6-05032	0.8
								72				0.9
<b>-HDC 7- 75</b>	2	7	27	45.4	—	75	41	—	28-50	28	HDA 6-05032	0.8
<b>-HDC 8- 45</b>	1	8	28	45.4	—	45	7	—	35-50	28	HDA 8-06020	0.7
- 75	75					41						
- 90	90					44						
<b>-105</b>	3				33	105	44	57	28-50	28	HDA 8-06032	0.9
								72				
<b>-HDC 9- 75</b>	2	9	29	45.4	—	75	41	—	28-50	28	HDA 8-06032	0.8
<b>-HDC10- 45</b>	1	10	30	46	—	45	7	—	45-55	33	HDA10-08015	0.7
- 75	75					36						
- 90	90					45						
<b>-105</b>	3					36	105	66	33-55	33	HDA10-08032	1.0
<b>-HDC11- 90</b>	3	11	31	46	34	90	51	45	33-55	33	HDA10-08032	0.9
<b>-HDC12- 45</b>	1	12	32	46	—	45	7	—	55-60	38	HDA12-10010	0.7
- 75	75					36						
- 90	90					45						
<b>-105</b>	3					38	105	67	38-60	38	HDA12-10032	1.0
												0.9
<b>-HDC13- 90</b>	3	13	33	46	36	90	45	51	38-60	38	HDA12-10032	0.9
<b>-HDC14- 90</b>	3	14	34	46	37	90	46	52	38-60	38	HDA12-10032	0.9
<b>-HDC15- 90</b>	2	15	37	46	—	90	47	—	43-70	43	HDA16-12037	1.0
<b>-HDC16- 45</b> ▲	1	16	38	46	—	45	7	—	70	43	—	0.7
- 75	75					35						
- 90	90					47						
	3								43-70	43	HDA16-12037	1.0
<b>-HDC18- 90</b>	4	18	36	51	44	90	31	41	43-70	43	HDA16-12037	1.0
<b>-HDC20- 60</b> ※	4	20	38	53	46	60	—	14	43-54	43	HDA16-12030	0.9
- 75						75	16	26	46-70			
- 90						90	31	41	43-70			
<b>-HDC25-105</b>	4	25	55	63	—	105	44	—	52-80	52	HDA25-16039	1.7
<b>-HDC32-105</b>	4	32	60	75	—	105	39	—	56-80	56	HDA25-16039	1.8

**Caution**

- Use only cutting tools that have a shank tolerance within h6.
- Do not use with cutting tools made with a flat on the shank (i.e.: Weldon type shank)
- Roughing endmills are not recommended for use with Hydraulic Chucks.
- Do not tighten the clamping screw without first inserting a cutting tool into the toolholder.
- Always insert the cutting tool into the Hydraulic Chuck beyond min. clamping length E.

- Adjustable cutter length H is the adjustable length using an optional Adjusting Screw.
- If a specific model number does not have a value for H, the inner bore is larger than the clamping diameter and use of Adjusting Screw is not available.
- Model with ▲ indication cannot use an Adjusting Screw. Model with ※ indication cannot use a Straight Collet.
- Add the letter "W" to Adjusting Screw model number for hexagon sockets on both sides. (e.g. HDA6-05020W) Adjusting Screw with ● indication is not available in W type.

For Straight Collet see back cover For Inner Bore Cleaner P4

# BBT40 series

Clamping range:  $\varnothing 4 - \varnothing 20$

## Slim Type

Slim design avoids interference.  
Ideal for various applications including mold making.



- Model Description
- BBT40 - HDC 4 - 60
- Projection Length
- Clamping Size
- Hydraulic Chuck
- BIG-PLUS BT No.

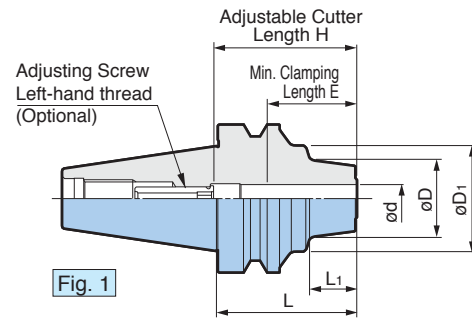

Fig. 1

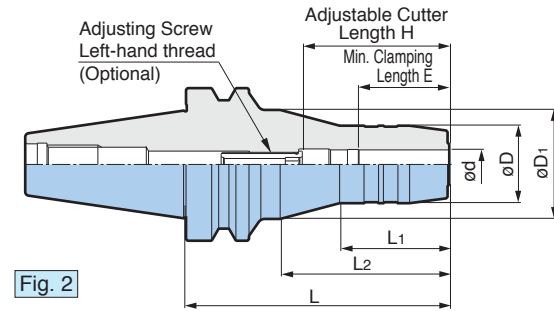

Fig. 2

## BBT40

BIG-PLUS tools can be used in machining centers with conventional spindles.

Model	Fig.	$\varnothing d$	$\varnothing D$	$\varnothing D_1$	L	$L_1$	$L_2$	Adjustable Cutter Length H	Min. Clamping Length E	Adjusting Screw (Optional)	Weight (kg)	
BBT40-HDC 4- 60 ▲	2	4	25	45	60	18	26	—	19	—	1.20	
- 75 ▲					75	30	42					1.30
- 90 ▲					90	38	57					1.35
-HDC 6- 60	2	6	26	45	60	19	—	28-50	28	HDA 6-05032	1.20	
- 90					90	—	50				1.35	
-110					110	44	70				1.50	
-135					135	—	95				1.65	
-165					165	—	119				1.90	
-HDC 7- 90	2	7	27	45	90	—	50	28-50	28	HDA 6-05032	1.30	
-110					110	44	70				1.50	
-135					135	—	95				1.65	
-165					165	—	119				1.90	
-HDC 8- 60					2	8	28				45	60
- 90	90	—	50	1.35								
-110	110	44	70	1.50								
-135	135	—	95	1.70								
-165	165	—	119	1.95								
-HDC 9- 90	2	9	29	45	90	—	50	28-50	28	HDA 8-06032	1.35	
-110					110	45	70				1.50	
-135					135	—	95				1.75	
-165					165	—	119				1.95	
-HDC10- 60					2	10	30				45	60
- 90	90	—	50	1.35								
-110	110	45	70	1.50								
-135	135	—	95	1.70								
-165	165	—	119	1.95								
-HDC11- 90	2	11	31	45	90	—	50	33-55	33	HDA10-08032	1.35	
-110					110	45	70				1.50	
-135					135	—	95				1.75	
-165					165	—	119				1.95	

- Model with ▲ indication cannot use an Adjusting Screw.
- If a specific model number does not have a value for H, the inner bore is larger than the clamping diameter and use of Adjusting Screw is not available.
- Add the letter "W" to Adjusting Screw model number for hexagon sockets on both sides. (e.g. HDA6-05032W)

## BBT40

BIG-PLUS tools can be used in machining centers with conventional spindles.

Model	Fig.	$\varnothing d$	$\varnothing D$	$\varnothing D_1$	L	$L_1$	$L_2$	Adjustable Cutter Length H	Min. Clamping Length E	Adjusting Screw (Optional)	Weight (kg)
BBT40-HDC12- 60	2	12	32	45	60	20	—	38-60	38	HDA12-10032	1.20
- 90					90	—	49				1.35
-110					110	45	69				1.55
-135					135	—	94				1.75
-165					165	—	119				1.95
-HDC13- 90	2	13	33	45	90	—	49	38-60	38	HDA12-10032	1.35
-110					110	45	69				1.55
-135					135	—	94				1.75
-HDC14- 90	2	14	34	45	90	—	49	38-60	38	HDA12-10032	1.35
-110					110	46	69				1.55
-135					135	—	94				1.75
-HDC15- 90	2	15	37	45	90	—	49	43-70	43	HDA16-12037	1.40
-110					110	47	69				1.60
-135					135	—	94				1.80
-HDC16- 75	2	16	38	45	75	35	36	43-70	43	HDA16-12037	1.30
- 90					90	—	49				1.40
-110					110	47	69				1.60
-135					135	—	94				1.85
-165					165	—	119				2.30
-HDC18- 90	2	18	40	45	90	—	49	43-70	43	HDA16-12037	1.45
-110					110	48	69				1.60
-135					135	—	94				1.85
-HDC20- 90	2	20	42	50	90	—	50	43-70	43	HDA16-12037	1.40
-110					110	48	70				1.70
-135					135	—	95				1.95
-165					165	—	119				2.35

- Adjustable cutter length H is the adjustable length using an optional Adjusting Screw.
- Add the letter "W" to Adjusting Screw model number for hexagon sockets on both sides. (e.g. HDA12-10032W)

**Caution**

- Use only cutting tools that have a shank tolerance within h6.
- Do not use with cutting tools made with a flat on the shank (i.e.: Weldon type shank)
- Roughing endmills are not recommended for use with Hydraulic Chucks.
- Do not tighten the clamping screw without first inserting a cutting tool into the toolholder.
- Always insert the cutting tool into the Hydraulic Chuck beyond min. clamping length E.

High Rigidity Type ideal for endmilling is also available.

For High Rigidity Type P5

For Straight Collet see back cover

## INNER BORE CLEANERS

Choose according to the chuck bore size.

For 6 to 12mm clamping bores

### WIPER CLEANER PAT.P

Easy cleaning of clamping bore by simply inserting and removing.

Model	$\varnothing D$	L
AWC 6	6	20
AWC 7	7	20
AWC 8	8	26
AWC 9	9	26
AWC10	10	31
AWC11	11	31
AWC12	12	31

For 13 to 42mm clamping bores

### TK CLEANER PAT.

Model	Bore Diameter( $\varnothing$ )	L	Leather Strips Qty.
TKC13	13	60	2
14	14		
15	15		
16	16		
18	18	70	3
20	20		
25	25		
32	32	100	4
40	40		
42	42		

# BBT40 series

Clamping range:  $\varnothing 20$ – $\varnothing 32$

## High Rigidity Type

Substantial body design eliminates chatter and deflection when endmilling.



Coolant Through Hole

● Model Description  
**BBT40** - **HDC** **20** **E** - **75**  
 ● Projection Length  
 ● High Rigidity Type  
 ● Clamping Size  
 ● Hydraulic Chuck  
 ● BIG-PLUS BT No.

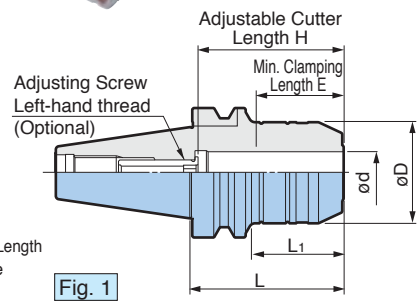

Fig. 1

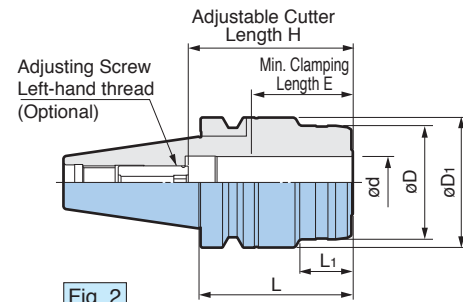

Fig. 2

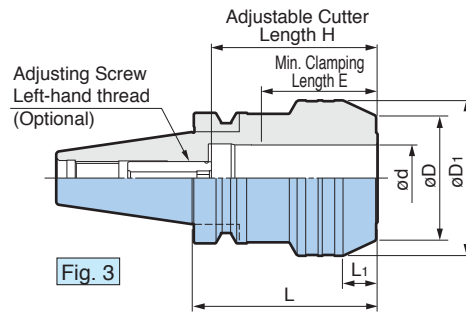

Fig. 3

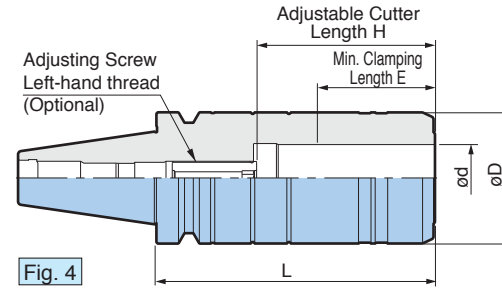

Fig. 4

## BBT40

BIG-PLUS tools can be used in machining centers with conventional spindles.

Model	Fig.	ød	øD	øD <sub>1</sub>	L	L <sub>1</sub>	Adjustable Cutter Length H	Min. Clamping Length E	Adjusting Screw (Optional)	Weight (kg)
<b>BBT40-HDC20E- 75</b>	1	20	49.2	—	75	45	43–70	43	HDA16-12037	1.40
<b>-HDC25E- 75</b>	2	25	55	62.9	75	25	52–80	52	HDA25-16033	1.80
<b>-110</b>					110					2.35
<b>-135</b>					135					2.95
<b>-165</b>					165					3.55
<b>-HDC32E- 90</b>	3	32	60	75	90	16	56–80.5	56	HDA25-16039	2.15
<b>-110</b>					110					2.55
<b>-135</b>					135					2.80
<b>-165</b>	2	—	62.9	62.9	165	—	56–85	—	—	3.40

- Adjustable cutter length H is the adjustable length using an optional Adjusting Screw.
- Add the letter "W" to Adjusting Screw model number for hexagon sockets on both sides. (e.g. HDA16-12037W)

**Caution**

- Use only cutting tools that have a shank tolerance within h6.
- Do not use with cutting tools made with a flat on the shank (i.e.: Weldon type shank).
- Roughing endmills are not recommended for use with Hydraulic Chucks.
- Do not tighten the clamping screw without first inserting a cutting tool into the toolholder.
- Always insert the cutting tool into the Hydraulic Chuck beyond min. clamping length E.

For Straight Collet see back cover

For Inner Bore Cleaner P4

# BBT50 series

Clamping range:  $\varnothing 6$ – $\varnothing 42$



Coolant Through Hole

● Model Description  
**BBT50** - **HDC** **6** **L** - **105**  
 ● Projection Length  
 ● Clamping Size  
 ● Hydraulic Chuck  
 ● BIG-PLUS BT No.

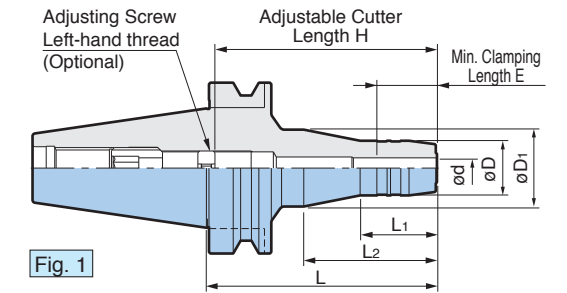

Fig. 1

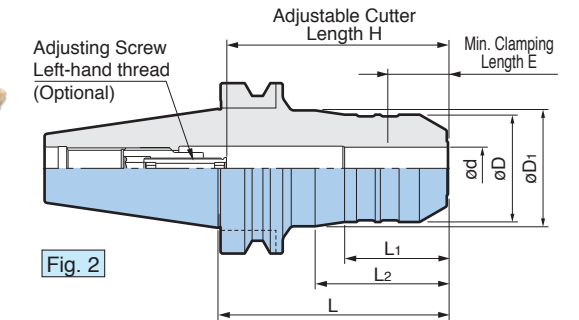

Fig. 2

## BBT50

BIG-PLUS tools can be used in machining centers with conventional spindles.

Model	Fig.	ød	øD	øD <sub>1</sub>	L	L <sub>1</sub>	L <sub>2</sub>	Adjustable Cutter Length H	Min. Clamping Length E	Max. insertion length	Adjusting Screw (Optional)	Weight (kg)
<b>BBT50-HDC 6L-105</b>	1	6	26	45	105	44	48	80–120	28	165	HDA6-20010	4.2
<b>-135</b>								110–150		195		4.3
<b>-150</b>								125–165		210		4.4
<b>-165</b>								140–180		225		4.5
<b>-HDC 8L-105</b>	1	8	28	45	105	45	48	80–120	28	165	HDA6-20010	4.2
<b>-135</b>								110–150		195		4.4
<b>-150</b>								125–165		210		4.5
<b>-165</b>								140–180		225		4.6
<b>-HDC10L-105</b>	1	10	30	45	105	45	48	80–120	33	165	HDA6-20010	4.2
<b>-135</b>								110–150		195		4.4
<b>-150</b>								125–165		210		4.5
<b>-165</b>								140–180		225		4.7
<b>-HDC12L-105</b>	1	12	32	45	105	45	48.5	80–120	38	165	HDA6-20010	4.2
<b>-135</b>								110–150		195		4.4
<b>-150</b>								125–165		210		4.6
<b>-165</b>								140–180		225		4.7
<b>-HDC16L- 90</b>	1	16	38	47	90	40	43.5	56– 96	43	150	HDA20-12047	4.1
<b>-105</b>								80–120		165		4.3
<b>-135</b>								110–150		195		4.6
<b>-150</b>								125–165		210		4.7
<b>-HDC20L- 90</b>	2	20	42	50	90	45	—	56– 96	43	150	HDA20-12047	4.2
<b>-105</b>								71–111		165		4.4
<b>-135</b>								101–141		195		4.7
<b>-150</b>								116–156		210		4.8
<b>-HDC25L- 90</b>	2	25	63	—	90	45.7	—	56– 96	52	113	HDA20-12047	4.7
<b>-105</b>								71–111		128		5.0
<b>-135</b>								101–141		158		5.7
<b>-150</b>								116–156		173		6.1
<b>-HDC32L- 90</b>	2	32	72	—	90	47	—	56– 96	56	112	HDA20-12047	4.7
<b>-105</b>								71–111		127		5.1
<b>-135</b>								101–141		157		6.0
<b>-165</b>								131–171		187		6.9
<b>-HDC42L-110</b>	2	42	96	—	110	72	—	76–116	65	132	HDA20-12047	6.1

- In the use of the Adjusting Screw in BBT50 series, please contact BIG agent because a guide screw needs to be set separately.
- Adjustable cutter length H is the adjustable length using an optional Adjusting Screw.
- Max. insertion length is the length when Adjusting Screw is not used.

**Caution**

- Use only cutting tools that have a shank tolerance within h6.
- Do not use with cutting tools made with a flat on the shank (i.e.: Weldon type shank).
- Roughing endmills are not recommended for use with Hydraulic Chucks.
- Do not tighten the clamping screw without first inserting a cutting tool into the toolholder.
- Always insert the cutting tool into the Hydraulic Chuck beyond min. clamping length E.

For Straight Collet see back cover

For Inner Bore Cleaner P4

# HSK series

Clamping range:  $\phi 4$ – $\phi 32$



- Model Description
- HSK-A40** - **HDC** **4** - **65**
- Projection Length
- Clamping Size
- Hydraulic Chuck
- HSK Form A & Size

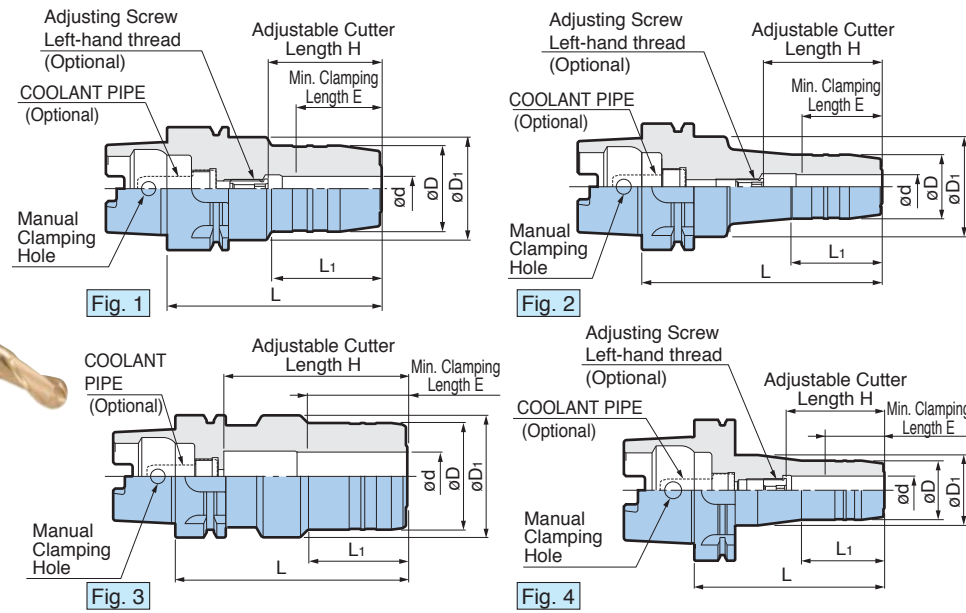

## HSK-A (DIN 69893-1) (ISO 12164)

Model	Fig.	$\phi d$	$\phi D$	$\phi D_1$	L	L <sub>1</sub>	Adjustable Cutter Length H	Min. Clamping Length E	Max min <sup>-1</sup>	Adjusting Screw (Optional)	Weight (kg)				
<b>HSK-A40-HDC 4- 65</b> ※	1	4	25	33.6	65	30	49	19	15,000	—	0.43				
<b>-HDC 6- 70</b>		6	26		70	36	28-36	28	17,000	HDA 6-05013	0.47				
<b>-HDC 7- 70</b>		7	27		70	36	28-36	28	17,000	HDA 6-05013	0.48				
<b>-HDC 8- 70</b>		8	28		70	36	28-36	28	17,000	HDA 6-05013	0.48				
<b>-HDC 9- 70</b>		9	29		70	36	28-36	28	17,000	HDA 6-05013	0.49				
<b>-HDC10- 75</b>		10	30		70	36	28-36	28	17,000	HDA 6-05013	0.50				
<b>-HDC11- 75</b>		11	31		70	36	28-36	28	17,000	HDA 6-05013	0.52				
<b>-HDC12- 80</b>		12	32		70	36	28-36	28	17,000	HDA 6-05013	0.55				
<b>HSK-A50-HDC 4- 75</b> ※		1	4		25	41.6	75	30	55	19	15,000	—	0.7		
<b>-HDC 6- 75</b>			6		26		75	32	28-37	28	17,000	HDA 6-05013	0.7		
<b>-HDC 8- 75</b>			8		28		75	32	28-37	28	17,000	HDA 6-05013	0.7		
<b>-HDC10- 80</b>			10		30		75	32	28-37	28	17,000	HDA 6-05013	0.7		
<b>-HDC12- 85</b>	12		32	75	32		28-37	28	17,000	HDA 6-05013	0.8				
<b>-HDC16- 90</b>	16		38	75	32		28-37	28	17,000	HDA 6-05013	0.9				
<b>-HDC20- 90</b> ▲	20		42	75	32		28-37	28	17,000	HDA 6-05013	0.9				
<b>-HDC25- 90</b> ※	25		55	62.9	90		64	43-51	43	13,000	—	1.3			
<b>HSK-A63-HDC 4- 75</b> ※	1		4	25	50		75	30	53	19	15,000	—	1.0		
<b>-HDC 6- 70</b> ※			6	26			70	24	46	—	17,000	HDA 6-05032	1.0		
<b>-120</b>			6	26			120	44	28-48	—	17,000	HDA 6-05032	1.4		
<b>-150</b>			6	26			150	44	28-48	—	17,000	HDA 6-05032	1.5		
<b>-HDC 7- 70</b> ※		7	27	70		24	46	—	17,000	HDA 6-05032	1.3				
<b>-120</b>		7	27	120		44	28-48	—	17,000	HDA 6-05032	1.5				
<b>-150</b>		7	27	150		44	28-48	—	17,000	HDA 6-05032	1.5				
<b>-HDC 8- 70</b> ※		8	28	70		24	46	—	17,000	HDA 8-06032	1.0				
<b>-120</b>		8	28	120		44	28-48	—	17,000	HDA 8-06032	1.3				
<b>-150</b>		8	28	150		44	28-48	—	17,000	HDA 8-06032	1.5				
<b>-HDC 9- 70</b> ※		2	9	29		50	70	24	46	—	15,000	—	1.1		
<b>-120</b>			9	29			120	44	28-48	—	15,000	HDA 8-06032	1.3		
<b>-150</b>	9		29	150	44		28-48	—	15,000	HDA 8-06032	1.6				
<b>-HDC10- 80</b> ※	10		30	50	80		35	55	—	15,000	HDA10-08032	1.3			
<b>-120</b>					80		35	55	—	15,000	HDA10-08032	1.6			
<b>-150</b>					80		35	55	—	15,000	HDA10-08032	1.6			
<b>-HDC11- 80</b> ※					11		31	50	120	45	33-53	—	15,000	HDA10-08032	1.4
<b>-120</b>									120	45	33-53	—	15,000	HDA10-08032	1.6
<b>-150</b>									120	45	33-53	—	15,000	HDA10-08032	1.6
<b>-HDC12- 85</b> ※	12		32	50	85		40	60	—	15,000	—	1.1			
<b>-120</b>					85		40	60	—	15,000	HDA12-10025	1.4			
<b>-150</b>					85		40	60	—	15,000	HDA12-10025	1.6			

For Straight Collet see back cover For Inner Bore Cleaner P4

## HSK-A (DIN 69893-1) (ISO 12164)

Model	Fig.	$\phi d$	$\phi D$	$\phi D_1$	L	L <sub>1</sub>	Adjustable Cutter Length H	Min. Clamping Length E	Max min <sup>-1</sup>	Adjusting Screw (Optional)	Weight (kg)			
<b>HSK-A 63-HDC13- 85</b> ※	2	13	33	50	85	40	60	38	15,000	—	1.2			
<b>-120</b>					120	45	38-58			HDA12-10025	1.4			
<b>-150</b>					150	45	38-58			HDA12-10025	1.7			
<b>-HDC14- 85</b> ※					14	34	85			40	60	—	1.2	
<b>-120</b>							120			45	38-58	HDA12-10025	1.4	
<b>-150</b>							150			45	38-58	HDA12-10025	1.7	
<b>-HDC15- 90</b> ※		15	37				90	40	60	—	1.3			
<b>-120</b>							120	45	58-68	HDA16-12015	1.5			
<b>-150</b>							150	45	38-68	HDA16-12037	1.9			
<b>-HDC16- 90</b> ※					16	38	90	40	65	—	1.3			
<b>-120</b>							120	46	58-68	HDA16-12015	1.5			
<b>-150</b>							150	46	43-68	HDA16-12037	1.9			
<b>-HDC18- 90</b> ※		18	40				90	40	65	—	1.3			
<b>-120</b>							120	46	58-68	HDA20-16015	1.6			
<b>-150</b>							150	46	43-68	HDA25-16039	2.0			
<b>-HDC20- 90</b> ※					20	42	90	40	65	—	1.3			
<b>-120</b>							120	48	58-68	HDA20-16015	1.6			
<b>-150</b>							150	48	43-68	HDA25-16039	2.0			
<b>-HDC25-120</b> ※		3	25				55	63	120	51	95	52	—	2.1
<b>-HDC32-125</b> ※									125	56	100	56	12,000	—
<b>HSK-A100-HDC 6- 75</b> ※		4	6				26	50	75	26	46	28	17,000	—
<b>-120</b>					120	44			28-48	HDA 6-05032	2.6			
<b>-165</b>					165	44			28-48	HDA 6-05032	2.9			
<b>-HDC 8- 75</b> ※					8	28			75	26	46			—
<b>-120</b>	120			44					28-48	HDA 8-06032	2.6			
<b>-165</b>	165			44					28-48	HDA 8-06032	3.0			
<b>-HDC10- 90</b> ※	10		30	90			42		61	—	2.5			
<b>-120</b>				120			45		33-53	HDA10-08032	2.7			
<b>-165</b>				165			45		33-53	HDA10-08032	3.1			
<b>-HDC12- 95</b> ※				12	32	95	47		63	—	2.5			
<b>-120</b>						120	47		38-58	HDA12-10025	2.7			
<b>-165</b>						165	47		38-58	HDA12-10032	3.1			
<b>-HDC16-100</b> ※	16		38			100	53		68	—	2.6			
<b>-135</b>						135	53		43-68	HDA16-12030	3.0			
<b>-165</b>						165	53		43-68	HDA16-12037	3.3			
<b>-HDC20-105</b> ※				20	42	105	59		73	—	2.7			
<b>-135</b>						135	59		58-68	HDA20-16015	3.1			
<b>-165</b>						165	59		43-68	HDA25-16039	3.6			
<b>-HDC25-110</b> ※	3		25			57	63		110	62	78	52	—	3.3
<b>-HDC32-110</b> ※									110	62	78	56	12,000	—

- Adjustable cutter length H is the adjustable length using an optional Adjusting Screw. Adjusting Screw cannot be used in Hydraulic Chuck with ※ mark. H length is equal to the max. insertion length.
- For additional balancing, please contact BIG agent.
- Straight Collet cannot be used in HSK-A50-HDC20-90 with ▲ mark.
- Collet Stopper (blue end piece) has to be removed when using Straight Collet in HSK-A63-HDC20-90.
- In some cases, machine rigidity and cutting tool balance may largely influence the max. RPM indicated. Gradually increase the RPM from a safe speed until the appropriate speed is reached.
- Coolant pipe is not included.
- Add the letter "W" to Adjusting Screw model number for hexagon sockets on both sides. (e.g. HDA12-10025W)

For Straight Collet see back cover For Inner Bore Cleaner P4

**Caution**

- Use only cutting tools that have a shank tolerance within h6.
- Do not use with cutting tools made with a flat on the shank (i.e.: Weldon type shank).
- Roughing endmills are not recommended for use with Hydraulic Chucks.
- Do not tighten the clamping screw without first inserting a cutting tool into the toolholder.
- Always insert the cutting tool into the Hydraulic Chuck beyond min. clamping length E.

**Caution**

For machines capable of supplying coolant through the spindle, the Coolant Pipe should be fitted to all HSK holders to protect against accidental selection of coolant.

### COOLANT PIPE (Optional)

#### ● Mono Block Type

Some machine tool builders may recommend the mono block type. Contact your machine builder and verify the proper style of Coolant Pipe to be selected.

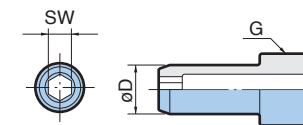

#### ● 1° Swing Type

DIN standard specifies ±1 degree of float. For proper installation, the special wrench is necessary.

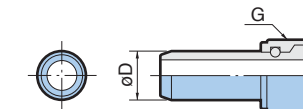

Model	$\phi D$	G	SW
<b>HSK 40-CP</b>	8	M12×P1	4
<b>50-CP</b>	10	M16×P1	5
<b>63-CP</b>	12	M18×P1	6
<b>100-CP</b>	16	M24×P1.5	8

Model	$\phi D$	G	Wrench Model (Optional)
<b>HSK 40-CPM</b>	8	M12×P1	CPW 40
<b>50-CPM</b>	10	M16×P1	CPW 50
<b>63-CPM</b>	12	M18×P1	CPW 63
<b>100-CPM</b>	16	M24×P1.5	CPW100

# BIG COROMANT CAPTO series

Clamping range:  $\phi 6$ – $\phi 32$

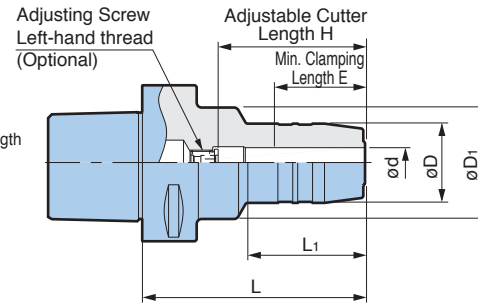
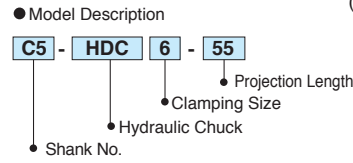

## BIG COROMANT CAPTO

Shank No.	Model	ød	øD	øD <sub>1</sub>	L	L <sub>1</sub>	Adjustable Cutter Length H	Min. Clamping Length E	Adjusting Screw (Optional)	Weight (kg)
C5	C5-HDC 6- 55 ※	6	26	45	55	18	48	28	—	0.8
	- 90				90	45	33–50		HDA 6-05020	1.0
	-120				120	28–50	HDA 6-05032		1.2	
	-HDC 7- 90	7	27	45	90	45	33–50	28	HDA 6-05020	1.1
	-120				120	28–50	HDA 6-05032		1.3	
	-HDC 8- 55 ※	8	28	45	55	18	48	28	—	0.8
	- 90				90	45	33–50		HDA 8-06020	1.1
	-120				120	28–50	HDA 8-06032		1.3	
	-HDC 9- 90	9	29	45	90	45	33–50	28	HDA 8-06020	1.1
	-120				120	28–50	HDA 8-06032		1.3	
	-HDC10- 60 ※	10	30	45	60	24	53	33	—	0.9
	- 90				90	45	43–55		HDA10-08015	1.1
	-120				120	33–54	HDA10-08032		1.3	
	-HDC11- 90	11	31	45	90	45	43–55	33	HDA10-08015	1.1
	-120				120	33–54	HDA10-08032		1.3	
	-HDC12- 60 ※	12	32	45	60	24	53	38	—	0.9
	- 90				90	48	53–60		HDA12-10010 ●	1.1
	-120				120	38–60	HDA12-10032		1.3	
	-HDC13- 90	13	33	45	90	48	53–60	38	HDA12-10010 ●	1.1
	-120				120	38–60	HDA12-10032		1.3	
	-HDC14- 90	14	34	45	90	48	53–60	38	HDA12-10010 ●	1.1
	-120				120	38–60	HDA12-10032		1.3	
	-HDC15- 90 ※	15	37	48	90	48	83	43	—	1.2
	-120				120	43–70	HDA16-12037		1.4	
	-HDC16- 75 ※				50	75	35		68	—
- 90 ※	16	38	48	48	90	83	43	—	1.2	
-120				46	120	48		43–70	HDA16-12037	1.4
-HDC18- 90 ※	18	40	48	48	90	83	43	—	1.2	
-120				49	120	48		43–70	HDA16-12037	1.5
-HDC20- 75 ※	20	42	50	52	75	35	43	—	1.1	
- 90 ※				50	90	48		83	—	1.2
-120				47	120	48		43–70	HDA16-12037	1.5
-HDC25- 90 ※	25	55	63	90	46	80	52	—	2.2	
-120				120	51	67–79		HDA20-16015	2.8	
-150				150	81	52–79		HDA25-16039	3.5	
-HDC32- 90 ※	32	75	63	90	43	81	56	—	2.8	
-120				63	—	120		—	66–78	HDA20-16015

- Adjustable cutter length H is the adjustable length using an optional Adjusting Screw.
  - Adjusting Screw cannot be used in Hydraulic Chuck with ※mark. H length is equal to the max. insertion length.
  - Add the letter "W" to Adjusting Screw model number for hexagon sockets on both sides. (e.g. HDA6-05020W)
- Adjusting Screw with ● indication is not available in W type.

For Straight Collet see back cover

For Inner Bore Cleaner P4

## BIG COROMANT CAPTO

Shank No.	Model	ød	øD	øD <sub>1</sub>	L	L <sub>1</sub>	Adjustable Cutter Length H	Min. Clamping Length E	Adjusting Screw (Optional)	Weight (kg)
C6	C6-HDC 6- 60 ※	6	26	45	60	18	51	28	—	1.4
	- 90				90	48	33–50		HDA 6-05020	1.5
	-120				120	45	28–50		HDA 6-05032	1.8
	-150				150	28–50	HDA 6-05032		2.0	
	-HDC 7- 90	7	27	45	90	48	33–50	28	HDA 6-05020	1.5
	-120				120	45	28–50		HDA 6-05032	1.8
	-150				150	28–50	HDA 6-05032		2.0	
	-HDC 8- 60 ※	8	28	45	60	18	51	28	—	1.4
	- 90				90	48	33–50		HDA 8-06020	1.6
	-120				120	45	28–50		HDA 8-06032	1.8
	-150				150	28–50	HDA 8-06032		2.0	
	-HDC 9- 90	9	29	45	90	48	33–50	28	HDA 8-06020	1.6
	-120				120	45	28–50		HDA 8-06032	1.8
	-150				150	28–50	HDA 8-06032		2.1	
	-HDC10- 65 ※	10	30	45	65	24	56	33	—	1.4
	- 90				90	48	43–55		HDA10-08015	1.6
	-120				120	45	33–54		HDA10-08032	1.8
	-150				150	33–54	HDA10-08032		2.1	
	-HDC11- 90	11	31	45	90	48	43–55	33	HDA10-08015	1.6
	-120				120	45	33–54		HDA10-08032	1.8
	-150				150	33–54	HDA10-08032		2.1	
	-HDC12- 65 ※	12	32	45	65	24	56	38	—	1.5
	- 90				90	48	48–60		HDA10-08015	1.6
	-120				120	48	38–60		HDA10-08032	1.8
	-150				150	38–60	HDA10-08032		2.1	
	-HDC13- 90	13	33	45	90	48	53–60	38	HDA12-10010 ●	1.6
	-120				120	48	38–60		HDA12-10032	1.8
	-150				150	38–60	HDA12-10032		2.1	
	-HDC14- 90	14	34	45	90	48	53–60	38	HDA12-10010 ●	1.6
	-120				120	48	38–60		HDA12-10032	1.9
	-150				150	38–60	HDA12-10032		2.1	
	-HDC15- 90 ※	15	37	48	90	48	81	43	—	1.7
-120	120				48	43–70	HDA16-12037		2.0	
-150	150				43–70	HDA16-12037	2.3			
-HDC16- 75 ※	16	38	48	50	75	35	43	—	1.6	
- 90 ※				47	90	48		81	—	1.7
-120				48	120	48		43–70	HDA16-12037	2.0
-150				48	150	48		43–70	HDA16-12037	2.3
-HDC18- 90 ※	18	40	48	48	90	66	43	—	1.7	
-120				49	120	48		43–70	HDA16-12037	2.0
-150				49	150	48		43–70	HDA16-12037	2.3
-HDC20- 75 ※	20	42	50	53	75	33	43	—	1.7	
- 90 ※				90	48	72		—	1.8	
-120				120	48	43–70		HDA16-12037	2.1	
-150				150	43–70	HDA16-12037		2.4		
-HDC25- 90 ※	25	55	63	90	46	80	52	—	2.2	
-120				120	51	67–79		HDA20-16015	2.8	
-150				150	81	52–79		HDA25-16039	3.5	
-HDC32- 90 ※	32	75	63	90	43	81	56	—	2.8	
-120				63	—	120		—	66–78	HDA20-16015

- Adjustable cutter length H is the adjustable length using an optional Adjusting Screw.
  - Adjusting Screw cannot be used in Hydraulic Chuck with ※mark. H length is equal to the max. insertion length.
  - Add the letter "W" to Adjusting Screw model number for hexagon sockets on both sides. (e.g. HDA6-05020W)
- Adjusting Screw with ● indication is not available in W type.

For Straight Collet see back cover

For Inner Bore Cleaner P4

**Caution**

- Use only cutting tools that have a shank tolerance within h6.
- Do not use with cutting tools made with a flat on the shank (i.e.: Weldon type shank)
- Roughing endmills are not recommended for use with Hydraulic Chucks.
- Do not tighten the clamping screw without first inserting a cutting tool into the toolholder.
- Always insert the cutting tool into the Hydraulic Chuck beyond min. clamping length E.