



Position detecting tool

# POINT CENTER

POINT CENTER

CATALOG No. EXm322

**NEW**

**NEW PRODUCTS**



## Precise detection of workpiece position in X & Y axes.

- **Special carbide stylus ball**  
Prevents corrosion, wear & swarf attachment for precise detection.
- **High-sensitive electronic circuit**  
Minimizes influence from electric resistance between machine spindle and workpiece.
- **Stainless steel body**  
Avoids rust and subsequent loss of accuracy.
- **Overtravel in X & Y axes**  
Protects the unit against damage from collision.
- **Compact size with  $\phi 10\text{mm}$  shank**



Full-scale

**Repeatability  $\pm 1\mu\text{m}$**

**BIG DAISHOWA SEIKI CO LTD**

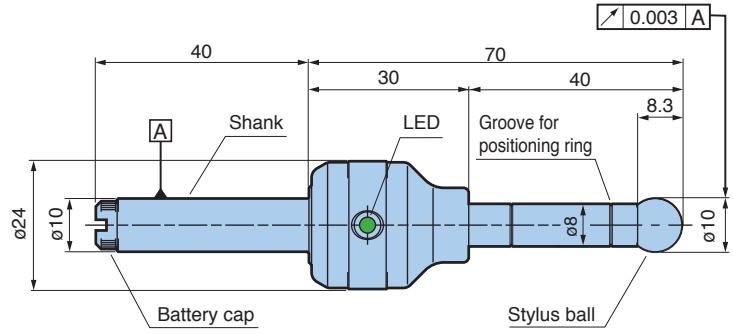

Model	<b>PC-10B</b>
Stylus ball repeatability	±1μm
Measuring direction	X & Y axes
Overtravel	±2mm
Touch signal	Green LED ON
Battery model	BR435 *
Battery life	20 hours (continuous use)
Weight	100g
Standard accessory	BR435×1P Positioning ring

● Positioning ring

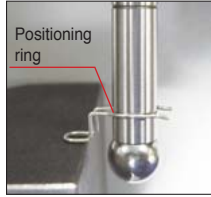

Aids to bring the stylus to the correct Z-axial position.

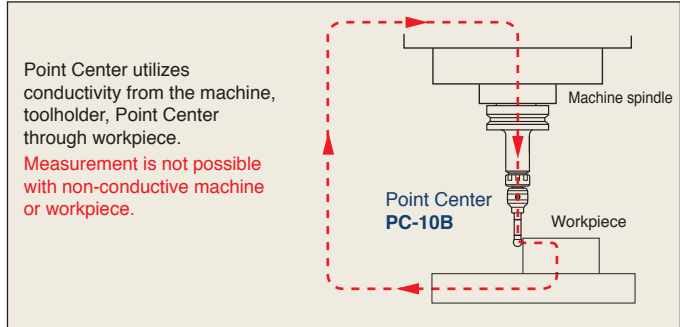

\* Panasonic lithium battery

Applications

Detecting reference position

Centering and measuring of I.D.

Measuring width

**BIG** Compact Sensor Series minimizes set-up time.

Tool offset sensor

Position detecting tool



For conductive materials  
**BASE MASTER**

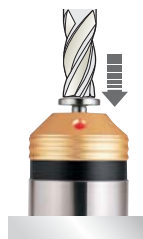

For all materials  
**BASE MASTER GOLD**



Cutter dia. 0.05mm-  
**BASE MASTER MICRO**



Large dial gauge, LED lamp and sound ease operation.  
**TOOL MASTER**

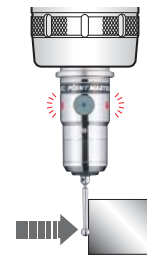

Precision 3-D touch sensor  
**POINT MASTER  
POINT MASTER PRO**



### BIG DAISHOWA SEIKI CO LTD

Takaramachi 5-2, Higashiosakashi  
Osaka 579-8025 JAPAN  
Phone : (+81)-72-982-8277 Fax : (+81)-72-982-8370  
<http://www.big-daishowa.com> E-mail: [export@big-net.ne.jp](mailto:export@big-net.ne.jp)



JQA-QMA11602  
AWAJI No.1 Factory  
JQA-QM3913  
FA Dept.

CATALOG No.EXm322-1110-1

Subject to technical changes by further developments.